

Fixed Infrared Cameras **PYROVIEW**

Non-contact Measurement of Temperature Distributions

-20 °C to 3000 °C

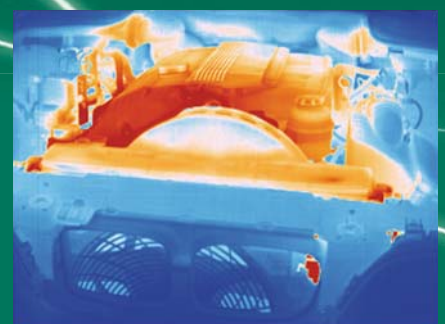

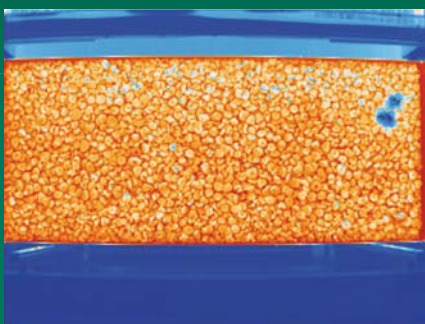

PYROVIEW

The world's most manifold fixed infrared

Our infrared camera series **PYROVIEW** allows you non-contact measurement of two-dimensional temperature distributions with high thermal and spatial resolution. All models are specifically designed for longterm use in fixed-mount applications.

Different standard, wide angle, tele and macro lenses as well as special combustion chamber lenses and borescope lenses with motor or manual focussing allow best possible measurement results. With real-time data acquisition via Fast Ethernet or Gigabit Ethernet images can be transferred to a computer. Stand-alone operation without computer is possible as well.

Alarm and threshold monitoring as well as triggered measurements are realized with galvanically isolated inputs (trigger) and outputs (alarm). The cameras have a large dynamic range and a 16-Bit analog digital converter.

We grant you two years warranty and customized system solutions with modified hardware and software. The PYROVIEW series made by DIAS Infrared is a unique infrared camera series that is optimally adjusted to your application.

To minimize physically caused temperature measurement failures resulting from emissivity inaccuracies, you should measure at a short wavelength. There are typical spectral ranges, recommended temperature ranges and application in the overview:

Material	Temperature range	Spectral range	Device type
Non-metals	-20 °C to 500 °C	8 µm to 14 µm	„L“
Glass surfaces	200 °C to 1250 °C	4.8 µm to 5.2 µm	„G“
Measurement through flames	600 °C to 1250 °C	about 3.9 µm	„F“
Ceramic, metals, graphite	100 °C to 500 °C	3.0 µm to 5.0 µm	„M“
Ceramic, metals, graphite	300 °C to 1200 °C	1.4 µm to 1.6 µm	„N“
Metals, glass melts	600 °C to 3000 °C	0.8 µm to 1.1 µm	„N“

Application areas of our infrared cameras PYROVIEW:

- Process control and monitoring
- Fire detection systems (paper stocks, waste bunkers, cities, forests,...)
- Quality control in metal, glass and cement industry
- Special measurements on glasses
- Traffic supervision
- Research and development

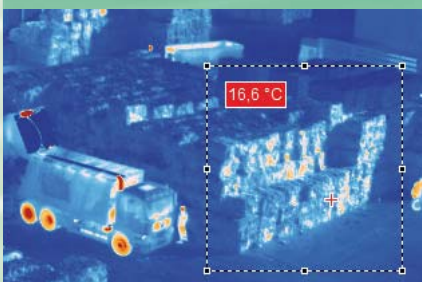

Space-saving but functional:
The compact+ housing for our PYROVIEW infrared cameras

camera series for industrial application

Camera type	Pixels	Spectral range	Temperature range ²	NETD ¹	Aperture angle ²	Motor focus	Housing
PYROVIEW 160L	160 × 120	8 μm to 14 μm	−20 °C to 120 °C, 0 °C to 500 °C	< 0,06 K (30 °C, 70 Hz)	25° × 19°, optional: 52° × 40°	no	compact+
PYROVIEW 320L	320 × 240	8 μm to 14 μm	−20 °C to 120 °C, 0 °C to 500 °C	< 0,12 K (30 °C, 70 Hz)	25° × 19°, optional: 52° × 40°	no	compact+
PYROVIEW 380L	384 × 288	8 μm to 14 μm	−20 °C to 120 °C, 0 °C to 500 °C	< 0,06 K (30 °C, 50 Hz)	30° × 23°, optional: 90° × 74°, 60° × 47°, 44° × 34°, 22° × 16°, 11° × 8°, macro 60 μm	yes	compact+ protection
PYROVIEW 640L	640 × 480	8 μm to 14 μm	−20 °C to 120 °C, 0 °C to 500 °C	< 0,08 K (30 °C, 50 Hz)	34° × 26°, optional: 90° × 74°, 67° × 52°, 25° × 19°, 12° × 9°, macro 30 μm	yes	compact+ protection
PYROVIEW 640M	640 × 480	3 μm to 5 μm	100 °C to 300 °C, 200 °C to 500 °C	< 0,5 K (200 °C, 50 Hz)	25° × 19°, optional: 75° × 60°, 59° × 46°, 43° × 33°, 12° × 9°	yes	compact+ protection
PYROVIEW 640G	640 × 480	4.8 μm to 5.2 μm	200 °C to 500 °C, 400 °C to 1250 °C	< 1 K (400 °C, 50 Hz)	25° × 19°, optional: 75° × 60°, 59° × 46°, 43° × 33°, 12° × 9°	yes	compact+ protection
PYROVIEW 640F	640 × 480	3.9 μm	600 °C to 1250 °C	< 1 K (600 °C, 50 Hz)	25° × 19°, optional: 75° × 60°, 59° × 46°, 43° × 33°, 12° × 9°	yes	compact+ protection
PYROVIEW 320N	320 × 256	1,4 μm to 1,6 μm	300 °C to 1200 °C	< 1 K (350 °C, 100 Hz)	24° × 19°, optional: 56° × 46°, 34° × 28°, 12° × 10°	yes	compact+ protection
PYROVIEW 512N	512 × 384	0.8 μm to 1.1 μm	600 °C to 1500 °C, optional 1400 °C to 3000 °C	< 1 K (600 °C, 60 Hz)	36° × 27°, optional: 51° × 40°, 26° × 19°, 19° × 14°, 13° × 9°, 9° × 7°	yes	compact+ protection
PYROVIEW 768N	768 × 576	0.8 μm to 1.1 μm	600 °C to 1500 °C, optional 1400 °C to 3000 °C	< 1 K (600 °C, 50 Hz)	39° × 30°, optional: 58° × 45° borescope lens: 74° × 59° (PYROINC 768N)	yes	compact+ protection

¹ Noise equivalent temperature range – specifications for black body radiator and ambient temperature 25 °C and maximum image frequency. ² Others on request.

Housing variety

There are two housing variants for our fixed PYROVIEW infrared cameras available by default:



compact+

- Aluminium compact housing
- Protection class IP54
- Dimensions 65 mm (L) × 160 mm (W) × 79 mm (H) (without lens and connectors)
- Operating temperature: −10 °C bis 50 °C



protection

- Industry protection housing
- Protection class IP65
- Stainless steel, with protection window, air purge unit and optional water cooling
- Diameter 110 mm, length 280 mm (without mechanical mounting and connectors)
- 6 bar max. water pressure, 2 bar max. air pressure
- Operating temperature: −25 °C to 150 °C (with water cooling)
−10 °C to 50 °C (without water cooling)

In order to protect the infrared cameras best possible there are no moving parts at the outside of the housing of "compact+" cameras with motor focus and all "protection" cameras. Special housings (weather protection housing, even with pan-tilt-unit, ATEX explosion protection housing) are available, too.

PYROVIEW

Dimensions, connectors and software

Dimensions

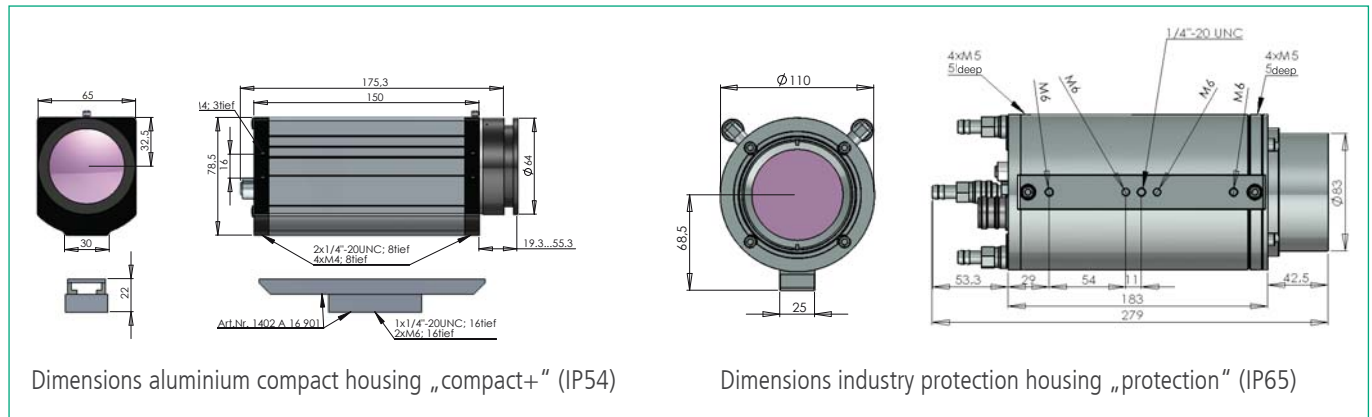

Dimensions aluminium compact housing „compact+“ (IP54)

Dimensions industry protection housing „protection“ (IP65)

Connectors

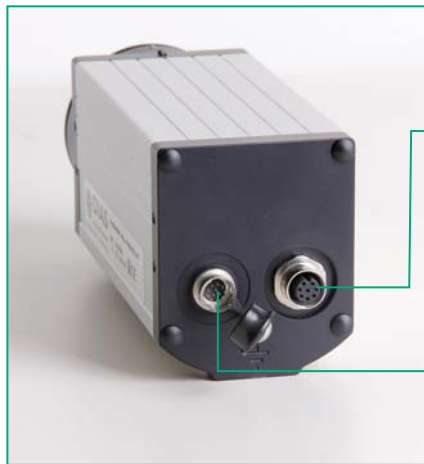

Ethernet (LAN)

- Infrared real-time data up to maximum image frequency (TCP/UDP)
- Web interface (status and image bar)
- PYROSOFT software
- GigE Vision® compatible
- Configuration for stand-alone operation

Inputs

- ➔ Power supply
- ➔ Trigger 1
- ➔ Trigger 2

Outputs

- Error signal/
- Alarm 1 ➔
- Synch signal/
- Alarm 2 ➔

Customized terminal box
(with power supply unit, alarm relay, controller, media converter,...)

Software

The powerful online software PYROSOFT for Windows ® allows you to control the camera and record, view, manipulate and store the measured data.

Special features are:

- Real-time data recording
- Definition of zones and monitoring of alarm thresholds
- Analysis of trends
- Data export (Text, Bitmap, Video)
- Support of process interfaces (e.g. profibus, analog and digital inputs and outputs)

For system integration the PYROSOFT DAQ software is available with a programming interface (Windows ®-DLL). The free software PYROSOFT Compact is delivered with every PYROVIEW infrared camera. For demanding application the versions PYROSOFT Professional and PYROSOFT Automation are available.

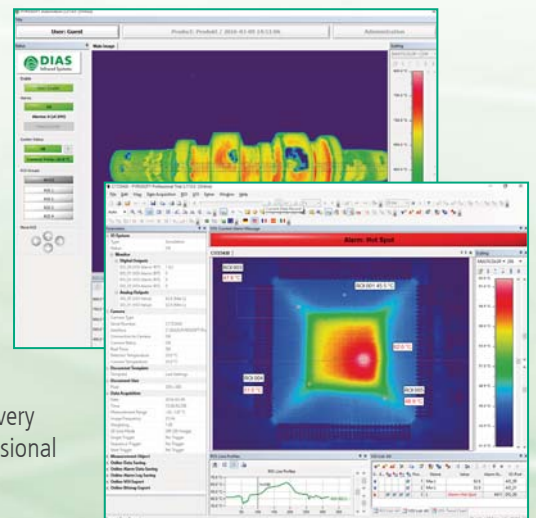

We are certified for many years according to ISO 9001

Phone: +49 351 896 74-0
Fax: +49 351 896 74-99
E-Mail: info@dias-infrared.de
Web: www.dias-infrared.com

DIAS Infrared GmbH
Pforzheimer Straße 21
01189 Dresden
Germany