

# ThermoWestronics

## Instructions to Upgrade Existing SV180 Firmware to Most Current Version

(Please note that these instructions are for SV180 units with floppy drives only. For all other drives such as zip and PCMCIA, please contact our Service Dept for assistance at 1-800-433-2184.)

### STEP 1

Make the upgrade disk set by...

1. Create two bootable disks by going to your DOS Window and typing the following command for each disk "format a: /s".
2. Create two new directories on your C: drive named "Disk1" and "Disk2".
3. Unzip the attached files accordingly to the appropriate directories. Please note that when you unzip the attached files, it will produce several files. Note that some of these files might contain a zipfile. Do NOT unzip any of these files, just put it on the disks the way it is.
4. Copy all of the files in the Disk1 folder to one of your bootable disks created earlier. Do the same for all of the files in the Disk2 folder. Now you should have two disks with files on it.

### STEP 2

Now you're ready to upgrade the SV180 firmware...

1. **Remove the SV180 slide-out chassis. We are going to work on the big board attached to it (also known as the CPU board).** There is an 8-position dip switch – S1 located to the rear left of the cpu board. Flip switch number 5 in the opposite direction. This is a required procedure!

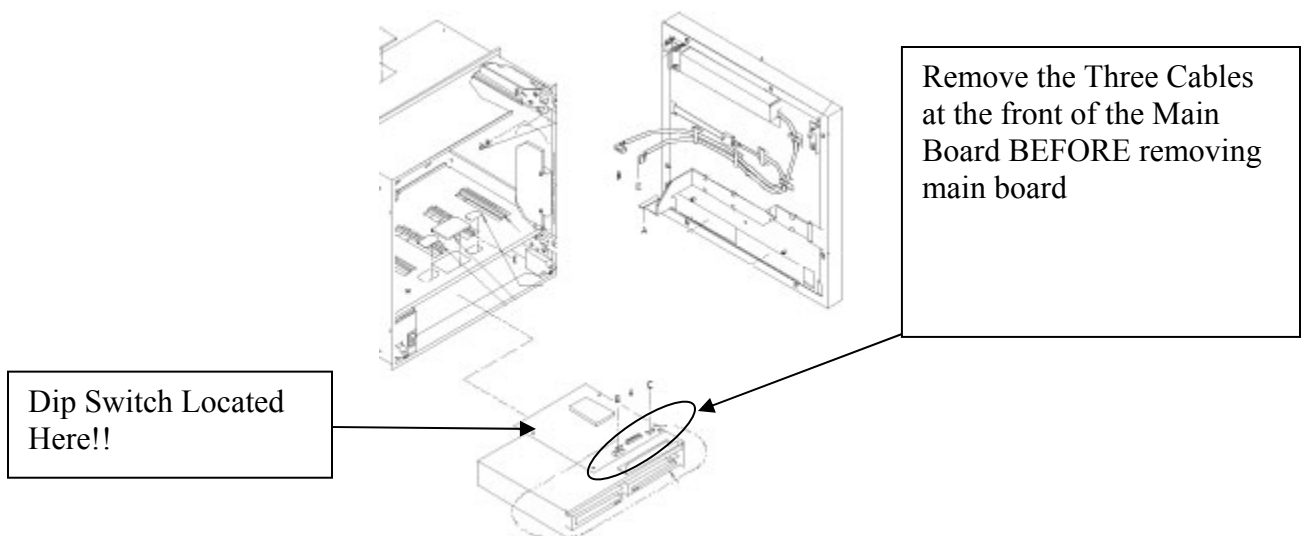

2. Replace the chassis and insert Disk1 into the SV180. Power-up the unit. Wait a minute or so. You should see the disk periodically being accessed. When the disk has finished loading, the SV180 will start beeping. The unit will beep 20 times and floppy drive light will go out.
3. Power down the unit. Remove Disk1. Insert Disk2. And power the unit up again.
5. As with the first disk, the floppy drive should become active, and the unit will start beeping when it completes the loading process, which is 10 times and the drive light will go out.
6. Power down the unit. **Move the switch number 5 back to its original location (SW1)!!!!!!**
7. When you next power-up, go to Function Menu and hit Version Key. Verify that you now have the correct version of firmware.
8. It might be possible that the time and date has been reset. Please check it and set the time and date accordingly.